

Zornberg, J.G., Costa, Y.D., and Vollenweider, B. (2004). "Mechanical Performance of a Prototype Embankment Backfill Built with Tire Shreds and Cohesive Soil." Proceedings of the 83rd Annual Meeting of the Transportation Research Board, Washington, D.C., January 11-15 (CD-ROM).

TRB 2004 ANNUAL MEETING

Title of Paper: Mechanical Performance of a Prototype Embankment Backfill Built With Tire Shreds and Cohesive Soil.

Submission Date: 08/01/03.

Number of Words: 6900.

Authors:

Jorge G. Zornberg, assistant professor, Civil Engineering Department, The University of Texas at Austin, 1 University Station C1792, Austin, TX, 78712-0280, Phone: (303) 492-4699, Fax: (303) 492-7317, e-mail: zornberg@colorado.edu (corresponding author).

Yuri D. Costa, visiting researcher, Department of Civil, Environmental and Architectural Engineering, University of Colorado at Boulder, 358 ECOT, Campus Box 428, Boulder, Colorado, 80309-0428, Phone: 303-786-0259, Fax: 303-492-7317, e-mail: ydjcosta@sc.usp.br.

Brent Vollenweider, former undergraduate student, Department of Civil, Environmental and Architectural Engineering, University of Colorado at Boulder, 358 ECOT, Campus Box 428, Boulder, Colorado, 80309-0428, Phone: 303-492-7112, Fax: 303-492-7317, e-mail: Brent.Vollenweider@Colorado.edu.

ABSTRACT

The mechanical response of a test embankment fill built with tire shreds and cohesive soil is evaluated. The test embankment consisted of three distinct sections, each 10 m (33 ft) long and 1.5 m (4.9 ft) high, composed by successive layers of soil and tire-shreds, a soil-tire shred mixture with 10% of tire shreds by weight, and pure soil. Immediately after construction, the embankment was exposed to heavy truck traffic. After 120 days following construction, settlement rate in both sections containing tire shreds converged to a value close to the observed in the fill section of pure soil. However, the section constructed with soil-tire shred mixture presented a better overall long-term behavior in comparison to the layered section, including smaller differential settlements. Insight into the *in-situ* compression, compaction and preparation characteristics of soil-tire shred mixtures and pure tire shreds as backfill materials is also provided herein.

In the last few decades, the enormous amount of scrap tires accumulated each year in storage areas has become a growing concern, especially in industrialized countries. In the United States, it is estimated that scrap tires are generated at an approximate rate of one unit per capita annually. The large stockpile sites not only present environmental problems, such as being breeding grounds for mosquitoes and rodents, but also pose serious fire hazards. Several cases have been documented in which stockpiles have experienced internal ignition, resulting in severely damaging fires (1). Although incineration for tire-derived fuel generation accounts for over 40% of the total tire production (2), the environmental impact associated with the increase of this recycling practice may be as negative as the growth of the storage areas itself.

Despite the fact that Civil Engineering is currently the second largest sector in the reuse of scrap tires, it still stands for only 14% of the total annual production (2). The spread of utilization of scrap tires in Civil Engineering applications is important because it represents an environmentally satisfactory means of giving this material a second life, and also contributes to the reduction of the use of non-renewable virgin construction materials. The smaller unit weight of fills built with scrap tires can be particularly advantageous in situations involving the settlement of compressible soils and the stability of retaining walls (3).

However, the practice of using whole tires and pure tire shreds (i.e., without mixing it with soil) has declined in the 1990s due to the failure of some major embankment fills in the US caused by exothermic reactions within the tire mass (1, 4). Conversely, no exothermic reactions have been reported for backfills of tire-shred mixtures to the present (5). Moreover, studies have shown that soil-tire shred mixtures have better mechanical properties than pure tire shreds, such as lower compressibility and higher shear strength (5, 6, 7, 8).

The main purpose of this paper is to evaluate the mechanical behavior of a prototype embankment fill built with tire shreds and cohesive soil. The embankment consisted of three cross-sections comprising distinct configurations, that is, with successive layers of soil and tire-shreds, with a soil-tire shred mixture, and with pure soil. Immediately after construction, the embankment was submitted to heavy truck traffic and settlements were monitored for over two years at different locations across the surface of each section. This investigation also provides insight into the *in-situ* compression, compaction and preparation characteristics of soil-tire shred mixtures and pure tire shreds as backfill materials. Although the mechanical characteristics of pure tire shreds and soil-tire shred composites have been addressed through laboratory studies, information regarding the field behavior of embankment fills made with these materials is still limited, particularly when cohesive soils are involved.

MATERIALS

The tire shreds used in this research were produced by means of a hammer mill at *Front Range Tire Recycle, Inc.*, a recycling and storage facility located in Sedalia, Colorado. This was also the place where the prototype embankment was constructed. The tire shreds had typical dimensions of 50.8 mm (2") to 152.4 mm (6") in length and 25.4 mm (1") in width, corresponding to aspect ratios of 1 to 3 (5). The specific gravity of the tire shreds is equal to 1.26, which compares well to the range of values reported in literature for tire shreds with steel belts (6). Water absorption of the rubber after soaking for five consecutive days is equal to 2.11%, which is in agreement with the results reported elsewhere (9).

The backfill soil used for the construction of the embankment is classified as a silty sand. Result of a standard Proctor test with the soil, revealed a maximum dry unit weight of 18.6 kN/m³ (118.4 pcf) and an optimum water content of 12.6%.

PRELIMINARY FIELD TESTING

A preliminary testing pad was constructed to evaluate the compaction and compressibility characteristics of the different materials used in the construction of the prototype embankment. An appropriate procedure for mixing the cohesive soil with the tire shreds was also devised. The testing pad consisted of four distinct sections with base dimensions of 3 x 3 m (9.8 x 9.8 ft). Each section was constructed in two lifts with thickness equal to 0.15 m (6"). The first two sections were built with mixtures containing 10 and 30% of tire shreds by weight, respectively. The third section was built with pure tire shreds, while the fourth section was constructed with pure soil. A sheepsfoot roller weighing 59.8 kN (6.7 tons) was used for compaction of the materials. Despite the different materials, the sections of the testing pad were compacted simultaneously to facilitate the construction process, following the suggestion of Dickson et al. (10).

Field Compaction Evaluation

Measurements of unit weight (γ) and water content (w) were taken with a surface nuclear gauge, following ASTM standards D 2933 and D 3017, respectively. Accuracy of the results with pure soil were estimated to be $\pm 1\%$ for w and $\pm 0.1 \text{ kN/m}^3$ ($\pm 0.6 \text{ pcf}$) for γ . Although calibrations in the laboratory were performed with larger samples in an attempt to reduce the influence of material heterogeneity due to the broad range of sizes and shapes of tire shreds, the accuracy of results of γ from field tests involving tire shreds are estimated to be within ± 0.1 ($\pm 0.6 \text{ pcf}$) and $\pm 0.8 \text{ kN/m}^3$ ($\pm 5.1 \text{ pcf}$) depending on the tire shred content.

Figure 1 shows the behavior of the dry unit weight (γ_d) of the tested materials (i.e., pure soil, mixtures, and pure tire shreds) with the number of passes of the compactor equipment, for the second lift of each section. Measurements started after the second pass and were repeated after every single pass (except for the fifth pass). The dry unit weight of the soil increased very slightly from the second to the third pass of the roller, and remained virtually constant after that point. After the third pass, γ_d reached a value of 17.9 kN/m^3 (113.9 pcf), corresponding to a relative compaction of 96% with respect to the maximum dry unit weight achieved in the laboratory. The soil-tire shred mixture with 10% of tire shreds presented slightly lower values of γ_d in comparison to that of pure soil. Very little change in γ_d after the second pass of the roller was also observed with this material, and a value of 17.1 kN/m^3 (108.8 pcf) was achieved after the third pass.

The tests in the tire shred layer and in the 30-% composite revealed some minor scattering in comparison to the previous tested materials, as expected, due to the presence of a larger amount of tire shreds. The mean dry unit weight achieved by the 30-% mixture is equal to 14.1 kN/m^3 (89.8 pcf). Despite the scattering, it is possible to affirm that there were no significant changes in γ_d after the second pass of the roller also with this material. The results with pure tire shreds are a little more scattered than the results of the 30-% mixture. Nevertheless, an average dry unit weight of 6.6 kN/m^3 (42 pcf) was found, which is within the range of typical values reported in literature (11).

As reported elsewhere (12), most of the observed compression with both mixtures and with pure tire shreds took place until the second pass of the roller, with very small improvement in compaction occurring afterwards. Compactive efforts did not increase the unit weight of pure soil after three passes of the roller. Based on these findings, the optimum number of passes for the construction of the prototype embankment was conservatively established as four.

Load-Displacement Behavior of Pure Tire Shreds

Figure 2 shows results of a plate load test conducted on the surface of the section of the testing pad containing pure tire shreds. The test was carried out following ASTM Standard D 1196-93, for use in the evaluation and design of airport and highway pavements. The test was performed using a square steel bearing plate with 0.3 m (1') in side and 19 mm (3/4") in thickness. The plate size and shape were chosen to simulate the loading area of a typical tire of a truck. The bearing plate was loaded in cumulative increments using a hydraulic jack and a hand pump assembly reacting against a wheel loader with an approximate total weight of 133.1 kN (15 tons). Load measurements were read from the hand pump manometer. Settlements were obtained using two dial gauges with a maximum stroke of 50 mm and a resolution of 0.01 mm, mounted on two reference beams with articulated magnetic bases. The dial gauges were displaced near the edges of opposite sides of the bearing plate, with the tips positioned directly on the surface of the bearing plate. The magnitude of the loading stages used in the test was previously defined based on a maximum load equal to the standard AASHTO H15 wheel load (53 kN or 12,000 lbs).

The shape of the curve shown in Figure 2 is quite similar to that of laterally confined tests on pure tire shreds published elsewhere (6, 13). Markedly high initial settlements are observed for stress increments lower than approximately 65 kPa (1,357 psf). However, as the stress level is increased, settlement variations are dramatically reduced, particularly after about 300 kPa (6,266 psf). The rebound upon unloading is very significant, with plastic settlement accounting for only about 11% of the total settlement. Since the tire shred layer was previously compacted, settlement is basically due to bending and elastic deformation of individual shreds, once most of settlement due to rearrangement and sliding of the shreds have occurred earlier during the compaction process.

In order to characterize the stiffness of the layer made with pure tire shreds for reference for field design parameters, it is necessary to calculate the modulus of subgrade reaction (K). For the tested material, K computed according to expression (1) is equal to 6 MN/m³ (38,193 pcf). The stress and settlement values considered in this equation correspond to the final loading stage. For a 0.3-m square footing, typical values of K reported in literature range from 13.5 (85,935 pcf) to 540 MN/m³ (3,437,420 pcf) (Fwa 2003).

$$K = \frac{\sigma}{s} \quad (1)$$

where: σ = stress level; s = settlement.

Once the stress-displacement response of the system is known, a field Young's modulus (E) can be obtained by backanalysis of expression (2), derived from the theory of elasticity. Typical values of Poisson ratio (ν) from uniaxial tests on pure tire shred specimens are in the range between 0.2 and 0.3 (6). Considering once again the full loading cycle, and assuming $\nu = 0.25$, $I_d = 1$, and $I_s I_h = 0.609$ (14), a value equal to 307 kPa (6,412 psf) is obtained for E.

$$E = \frac{\sigma B(1-\nu^2)}{s} I_s I_d I_h \quad (2)$$

where: B = plate diameter or width; I_s = shape/stiffness factor; I_d = embedment factor; I_h = layer thickness factor.

Field Mixing Methods

In order to come up with a fast and efficient *in-situ* method for producing a thoroughly mixture of tire shreds and cohesive soil using equipment typically available in highway construction, five different procedures were tested prior to the construction of the prototype embankment. The

characteristics of each method, including their advantages and shortcomings are described in Table 1.

Mixing was very difficult to control in method 1, and a considerable amount of on-site soil was mixed together with the imported soil and the tire-shreds. Method 5 was discarded because it did not generate a homogeneous mixture. Methods 3 and 4 provided a relatively fast preparation of thoroughly homogeneous mixtures, but required three pieces of equipment. Although a few slower than methods 3 and 4, method 2 was chosen over the others for the final embankment project because it required only one piece of equipment and generated satisfactory mixtures. None of the mixing procedures took less than 15 minutes to be prepared.

This investigation was also useful to verify that large-scale production of the composite containing 30% of tire shreds by weight was not feasible due to difficulties involved in preparing a homogeneous mixture with the cohesive soil. Problems in mixing tire shreds and cohesive soils in the field were anticipated by Dickson et al. (6).

PROTOTYPE EMBANKMENT DESIGN AND CONSTRUCTION

The prototype embankment was constructed on an access road in the recycling facility mentioned above and included three distinct sections with 10 m (33') in length and 1.5 m (4.9') in height. Each section was designed and constructed with a base width of 17.5 m (57.4') and a crest width of 9 m (29.5'). The west and east side slopes of the embankment had an inclination of 3H:1V and 2.5H:1V, respectively, and were covered with a 0.3-m (1') thick layer of soil. Figure 3 presents a plan view of the embankment geometry, including the location of the instrumentation used to monitor its performance and the area of the plate load tests. Construction of the embankment was finished in approximately one month.

Figure 4 illustrates the geometric characteristics of the constructed cross-sections. The first section of the embankment (section A) had two layers of pure tire shreds with 0.15 m (6") in thickness, and two 0.6-m (2') thick layers of pure soil. Section B comprised a soil-tire shred mixture with a tire shred content of 10% by weight, produced according to mixing method 2 depicted above, and a soil cover with 0.3 m (1') in thickness. In order to allow comparisons, both sections were constructed with the same amount of tire shreds. Section C was built with pure soil, and had the solely purpose of serving as a basis to assess the behavior of the other two sections.

The first step in the construction of the embankment was to excavate the access road up to the subgrade and then leveling the surface of the foundation soil. The same equipment used in the testing pad, that is, a front-end loader and a sheepsfoot roller weighing 59.8 kN (6.7 tons), was used to build the prototype embankment. Since no cross-contamination of materials was previously verified, it was decided to keep the simultaneous compaction technique used in the testing pad.

Based on the previous analysis with the testing pad, three passes of the roller was verified to be sufficient for all materials to achieve a satisfactory degree of compaction. However, each lift of the embankment was conservatively compacted in four passes. Field control was accomplished with a nuclear gauge after the compaction of each lift, and the results showed a good agreement with the results obtained in the testing pad. As in the testing pad, a relative compaction of 96% for the soil was achieved.

After completion of construction of the embankment, a total of 15 steel stakes with 0.45 m (18") in length were properly installed on the surface of the embankment in order to monitor the settlement of the various sections. The location of the survey instrumentation in the

embankment is provided in Figures 3 and 4. The elevation of the points, measured with a theodolite with accuracy of ± 1 mm (± 0.04 "), was based on the elevation of a 1.5-m (5') tall plastic pole cemented into the on-site soil. Immediately after installation of the survey instrumentation, the embankment was exposed to heavy truck traffic and settlements were monitored for 824 days. An average of 20 trucks per day crossed the embankment in both directions. The maximum registered weight of an individual truck crossing the embankment was 111 kN (12.4 tons).

PERFORMANCE OF THE PROTOTYPE EMBANKMENT EXPOSED TO TRAFFIC

Similarly to pure soil, settlement of fills constructed with soil-tire shred mixtures can be classified into initial, primary consolidation, and secondary compression, and all these components may occur simultaneously. If the composite is in an unsaturated state, consolidation in that case means dissipation of excess of pore-air and pore-water pressures (15). Distortion, bending and reorientation of the tire shreds embedded in the soil matrix, as well as elastic deformation of individual tire shreds upon loading are part of the compression mechanisms of such fills. The interaction between tire shreds and soil particles, resulting in interface friction, must also be considered as part of the process. Soil-tire shred interface friction angle is about 26° for cohesive soil under drained conditions and 30° for dry sand (16). Summed up, all these mechanisms compose a highly complex scenario.

Settlement of fills of pure tire shreds is basically due to distortion, bending, reorientation, and elastic deformation of tire shreds. In this case, the large voids in the tire shred mass increase the influence of these mechanisms in the overall behavior of the material. As a result, settlement of such fills is generally higher than that of fills of soil-tire shred composites. Moreover, settlement of pure tire shred fills may also be caused by the migration of soil particles from the cover layer (or from upper layers, in the case of layered systems) into the voids of the tire shred mass. This is analogous to a process that takes place in landfills known as raveling (17) (the same designation will be used herein).

Raveling is usually accompanied by the formation of potholes on the embankment surface. A geotextile is commonly used as a separation element between the soil and tire shred layers to prevent raveling. In this research, it was chosen to build the embankment without separation elements to evaluate the extent of raveling with cohesive soils. After over two years of traffic, the layered section (A) developed a few small potholes, comparable to what was observed on the 10-% mixture section (B). This suggests that raveling was negligible in section A. Whenever possible, the design of embankments involving layers of pure tire shreds and cohesive soil should take advantage of the soil cohesion over separation elements.

Settlement as a function of time after the beginning of traffic is presented in Figure 5. The data in this figure was collected at the center of the crest of each section of the embankment (Figures 3 and 4). In general, sections A and B showed a satisfactory long-term performance. Settlement measured in section A, built with consecutive layers, was larger than in section B, made with the soil-tire shred composite. However, settlements of both sections were higher than in section C (soil only), which showed settlements not greater than 65 mm (2.6"). At the end of the survey period (824 days), the final settlements of sections A and B were 87 and 62% larger than the final settlement of section C, respectively.

Results of Figure 5 also indicate that settlements were more pronounced during the first 120 days in all sections, dropping considerably after that period. Settlement rate (m) of each section from the beginning of the survey until the first 120 days (stage I), and from that point to

the end of the survey (stage II) is presented in Table 2. During stage I, settlement rate at section A is twice as high as at section C. Accordingly, m at section B is 63% more pronounced than at section C during the same period. Throughout stage II, sections A and B show similar settlement rates, about 0.04 mm/day (0.0016 inches/day), less than one tenth of the values of m observed at stage I. This value is very close to that of section C.

According to Figure 2, the portion of settlement in section A due to the initial compression of the two layers of pure tire shreds caused by the self weight of the embankment is about 40 mm (1.6"). This accounts for almost 45% of the total settlement experienced by this section during the first 120 days after construction and beginning of traffic.

Figure 6 shows profiles composed by settlements measured in five distinct locations across the surface of each section (see Figures 3 and 4). The data in the figure correspond to 38, 120 and 824 days of survey. In general, section C presented the smallest settlements in all measured locations, followed by sections B and A, respectively. After 38 days (Figure 6a), displacements of sections B and C were very close at the slopes. On the other hand, section A presents slightly higher displacements at the slopes and at the center. A not very clear pattern is observed at the shoulders. After 120 days (Figure 6b), settlements of section A become noticeably larger in comparison to the other sections, particularly at the slopes. Although settlements of section B became more pronounced at the center and shoulders with respect to section C, settlements of both sections remained very close at the slopes. Figure 6c shows that, at the conclusion of the survey period, 824 days, settlements at the slopes and shoulders of section A became markedly pronounced, much larger than at the center. The self-weight of the embankment fill and the presence of the transient loading cause the two layers of pure tire shreds to compresses more near the edges of the embankment, due to the lower confinement in those regions, according to the behavior shown in Figure 2.

Angular distortions (β), computed according to expression 3 from the differential settlements observed at the shoulders and the center of the sections (points 1, 2, and 3 in Figures 3, 4 and 6), are shown in Table 3. The settlement data belongs to the final stage of the survey, 824 days.

$$\beta_{ij} = \frac{\Delta s_{ij}}{L_{ij}} \quad (3)$$

where: Δs_{ij} = differential settlement between survey points i and j ; L_{ij} = distance between survey points i and j .

Section C presented comparatively small angular distortions, comparable to the safety limit recommended for flexible brick walls, 1/150 (18). Except for the distortion between points 2 and 3, which was somewhat elevated, the response of section B was similar to that of section C. As verified previously, section A presented very large differential settlements, with the shoulders settling more than the center.

SUMMARY AND CONCLUSIONS

A field investigation was conducted to assess the mechanical behavior of an experimental embankment fill built with tire shreds and cohesive soil. Sections including successive layers of soil and tire-shreds, a soil-tire shred composite, and pure soil were evaluated. Immediately after construction, the embankment was submitted to heavy truck traffic and settlements were monitored for over two years at different locations across the surface of each section.

The results indicate that the embankment sections built with tire shreds and cohesive soil showed satisfactory long-term performances during traffic exposure. In all sections, most of the

compression took place within the first 120 days following construction. Settlements of both fills containing tire shreds were higher than that of the section of pure soil. However, after 120 days, settlement rate in both sections converged to a value close to the observed in the fill section of pure soil. The section containing the soil-tire shred mixture presented a better overall time-dependent performance in comparison to the layered section, including smaller differential settlements.

Depending on the content of tire shreds and on the cohesion of the soil, large volumes of homogeneous tire shred-cohesive soil composites may be difficult to be prepared in the field with machinery commonly used for embankment construction. Particularly, production of a mixture with 30% of tire shreds was not feasible with the soil tested herein. However, a single wheel loader with a bucket equipped with a tooth edge set proved to be very efficient in making large quantities of a homogeneous mixture with 10% of tire shreds by weight.

ACKNOWLEDGMENTS

The authors wish to thank Mr. Richard Welle, Erich Kroll, Angela Argentati, Chunling Li, Bill Zietlow, Tad Pfeffer, John McCartney, and Alexandre Cabral for their contribution.

REFERENCES

1. Humphrey, D.N. *Investigation of Exothermic Reaction in Tire Shred Fill Located on SR 100 in Ilwaco, Washington*. Prepared for the Federal Highway Administration. Washington, D.C., 1996, 60 p.
2. RMA. U.S. Scrap Tire Markets 2001. *Publication #ST-01*. Rubber Manufacturers Association, 2002, 37p.
3. Tweedie, J. J., D. N. Humphrey, and T. C. Sandford. Tire Shreds as Lightweight Retaining Wall Backfill: Active Conditions. *Journal of Geotechnical and Geoenvironmental Engineering*, ASCE, Vol. 124, No. 11, 1998, pp. 1061-1070.
4. Gacke, S., M. Lee, and N. Boyd. Field Performance and Mitigation of Shredded Tire Embankment. In *Transportation Research Record 1577*, TRB, National Research Council, Washington, D.C., 1998, pp. 81-89.
5. Zornberg, J. G., A. R. Cabral, and C. Viratjandr. Behavior of Tire Shred-Sand Mixtures. *Canadian Geotechnical Journal*, 2003, in press.
6. Edil, T. B., and P. J. Bosscher. Engineering Properties of Tire Chips and Soil Mixtures. *Geotechnical Testing Journal*, ASTM, Vol. 17, No. 4, 1994, pp. 453-464.
7. Foose, G. J., C. H. Benson, and P. J. Bosscher. Sand Reinforced with Shredded Waste Tires. *Journal of Geotechnical Engineering*, ASCE, Vol. 122, n.9, 1996, pp. 760-767.
8. Masad, E., R. Taha, C. Ho, and T. Papagiannakis. Engineering Properties of Tire/Soil Mixtures as Lightweight Fill Material. *Geotechnical Testing Journal*, ASTM, Vol. 19, No. 3, 1996, pp. 297-304.
9. Humphrey, D.N. *Civil Engineering Applications of Tire Shreds: A Short Course*. Organized by GeoSyntec Consultants, Inc., June, 1997.
10. Dickson, T. H., D. F. Dwyer, and D. N. Humphrey. Prototype Tire-Shred Embankment Construction. In *Transportation Research Record 1755*, TRB, National Research Council, Washington, D.C., 2001, pp. 160-167.
11. Reddy, K. R., and A. Marella. Properties of Different Size Scrap Tire Shreds: Implications on Using as Drainage Material in Landfill Cover Systems. *Proceedings, 17th International Conference on Solid Waste Technology and Management*, October, 2001, Philadelphia, PA.

12. Bosscher, P. J., T. B. Edil, and N. Eldin. Construction and Performance of a Shredded Waste Tire Test Embankment. In *Transportation Research Record 1345*, TRB, National Research Council, Washington, D.C., 1992, pp. 44-52.
13. Ahmed, I., and C. W. Lovell. Rubber Soils as Lightweight Geomaterials. In *Transportation Research Record 1422*, TRB, National Research Council, Washington, D.C., 1993, pp. 61-70.
14. Harr, M. E. *Foundations of Theoretical Soil Mechanics*, McGraw-Hill, New York, 1966.
15. Fredlund, D. G., and H. Rahardjo. *Soil Mechanics for Unsaturated Soils*, John Wiley & Sons, New York, 1993.
16. Garga, V. K., and V. O'Shaughnessy. Tire-reinforced earthfill. Part 1: Construction of a test fill, performance, and retaining wall design. *Canadian Geotechnical Journal*, Vol. 37 No.1, 2000, pp. 75-96.
17. Quian, X., R. M. Koerner, and D. H. Gray. *Geotechnical Aspects of Landfill Design and Construction*, Prentice Hall, New Jersey, 2002.
18. Bjerrum, L. Allowable Settlement of Structures. *Proceedings, Third European Conf. Soil Mech. Found. Eng.*, Weisbaden, Germany, 1963.

LIST OF TABLES AND FIGURES

TABLE 1 Methods Evaluated to Produce a Homogeneous Soil-Tire Shred Mixture

TABLE 2 Settlement Rate of Sections

TABLE 3 Angular Distortions on Top Surface of Sections A, B and C

FIGURE 1 Dry Unit Weight Versus Number of Passes For the Different Tested Materials.

FIGURE 2 Stress-Settlement Relationship of Pure Tire Shreds.

FIGURE 3 Plan View of the Prototype Embankment. Dimensions in meters.

FIGURE 4 Prototype Embankment Cross-Sections Characteristics. Dimensions in meters.

FIGURE 5 Settlement of Each Section After Construction and Submission to Traffic.

FIGURE 6 Settlement Profiles of the Embankment Cross-Sections at 38, 120 and 824 Days. a) After 38 days, b) after 120 days, and c) after 824 days following construction. Displacements are Magnified by a Scale Factor of 5.

TABLE 1 Methods Evaluated to Produce a Homogeneous Soil-Tire Shred Mixture

Method	Used equipment	Procedure	Comments
1	One wheel front-end loader, with bucket equipped with a straight blade edge and capacity of 1.6 m ³ .	a) An amount of tire shreds was loaded and dumped on the onsite soil; b) an amount of soil was loaded and dumped over the tire shreds; c) both materials were flipped over and mixed together with the loader.	A poor mix was obtained with this method. On-site soil was mixed along into the mixture, since digging under the shreds was impossible to be accurately controlled.
2	One wheel front-end loader, with bucket equipped with a tooth set edge and capacity of 1.6 m ³ .	Same as method 1.	Although in a much lesser extent comparatively to method 1, on-site soil was mixed along into the mixture. A comparatively better mixture was generated with the bucket equipped with the tooth set.
3	Two wheel front-end loaders similar to that used in method 1.	a) An amount of tire shreds was dumped from bucket of loader 1 into bucket of loader 2; b) an amount of soil was dumped from bucket of loader 1 into bucket of loader 2; c) the total volume was dumped into the bucket of loader 1, and then back to loader 2.	This method generated a cleaner mixture and was 2 minutes faster than methods 1 and 2. The major disadvantage is that it required two pieces of equipment. Also, a considerable amount of mixture fell outside the buckets during the mixing process.
4	Two wheel front-end loaders as used in method 3 and a dump truck.	a) An amount of soil was loaded into the truck with loader 1; b) an amount of tire shreds was loaded into truck with loader 2; c) the loaders continued this process until all of the mixture had been placed into the dump truck; d) the mixture was dumped on the ground.	This method was 3 minutes faster than method 3, and also generated cleaner mixtures without losses. However, it mobilized three pieced of equipment.
5	Wheel front-end loaders used in method 4 and a scraper.	a) The loaders dumped a layer of tire shreds next to a layer of soil; b) the scraper runner across these layers in order to mix them.	Materials were not mixed thoroughly with this method.

TABLE 2 Settlement Rate of Sections

Period after construction	Settlement rate, $m \times 10^{-2}$ (mm/day)		
	Section A	Section B	Section C
0 to 120 days (stage I)	76.0	62	38
120 to 824 days (stage II)	4.1	4.2	2.7

TABLE 3 Angular Distortions on Top Surface of Sections A, B and C

Section	Angular distortion, β		
	β_{13}	β_{12}	β_{23}
Layered (A)	1/592	1/18	1/19
Mixture (B)	1/113	1/169	1/42
Soil only (C)	1/118	1/167	1/92

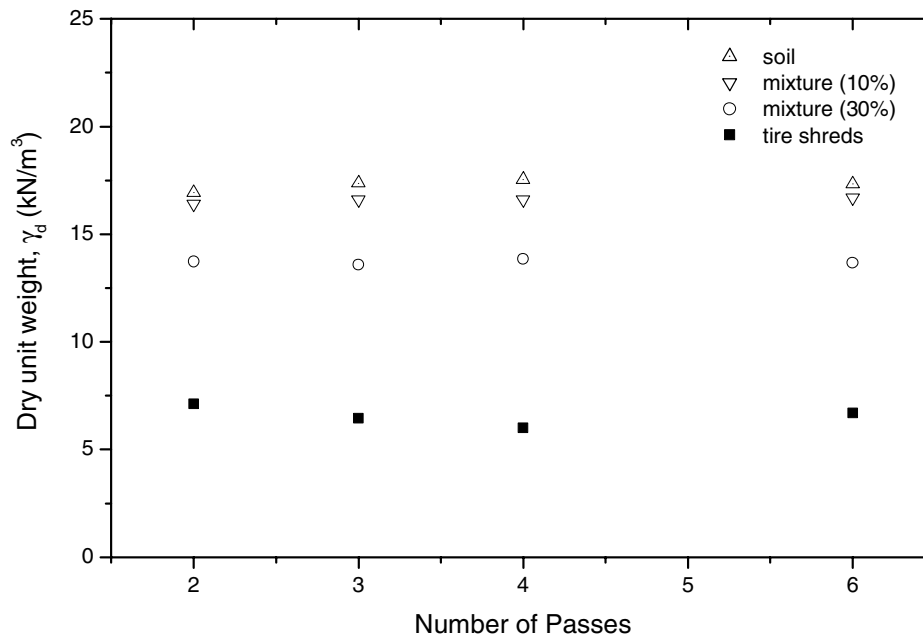

FIGURE 1 Dry Unit Weight Versus Number of Passes For the Different Tested Materials.

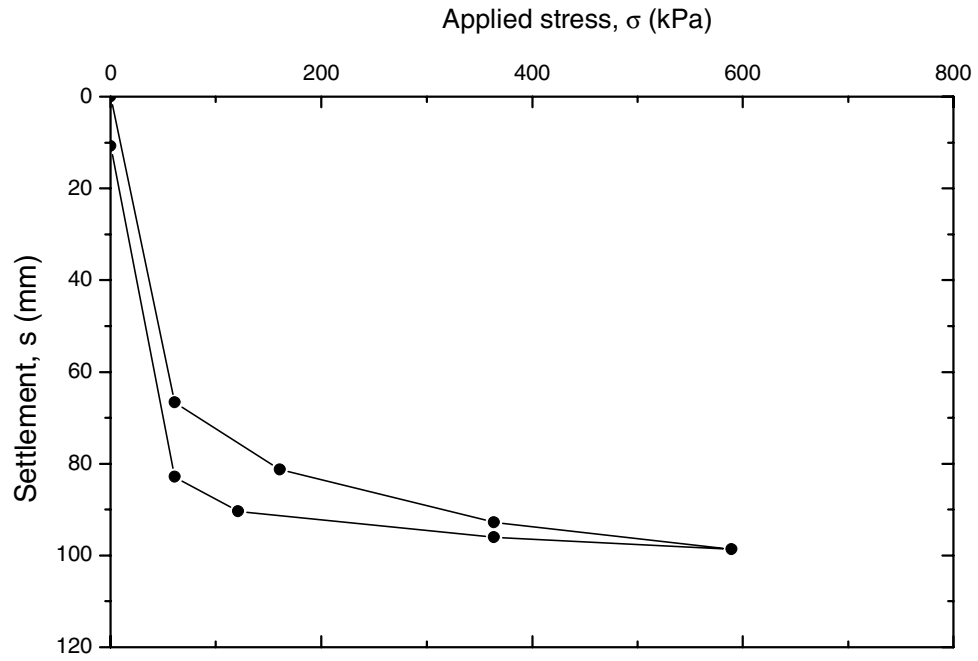

FIGURE 2 Stress-Settlement Relationship of Pure Tire Shreds.

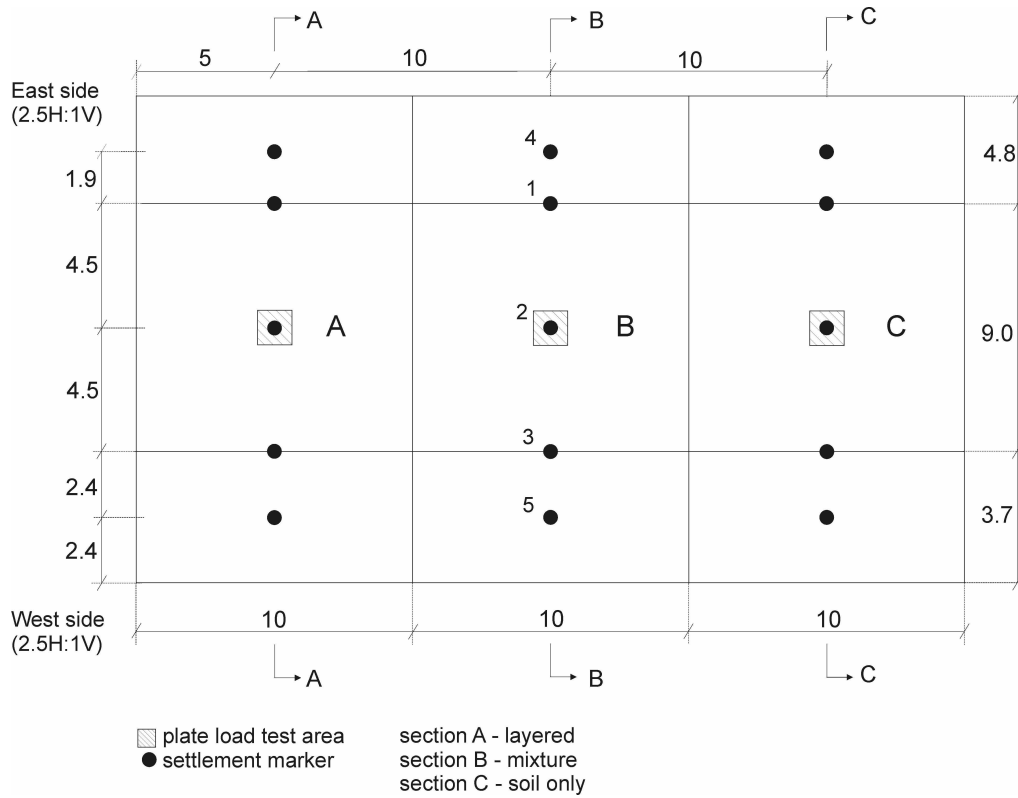

FIGURE 3 Plan View of the Prototype Embankment. Dimensions in meters.

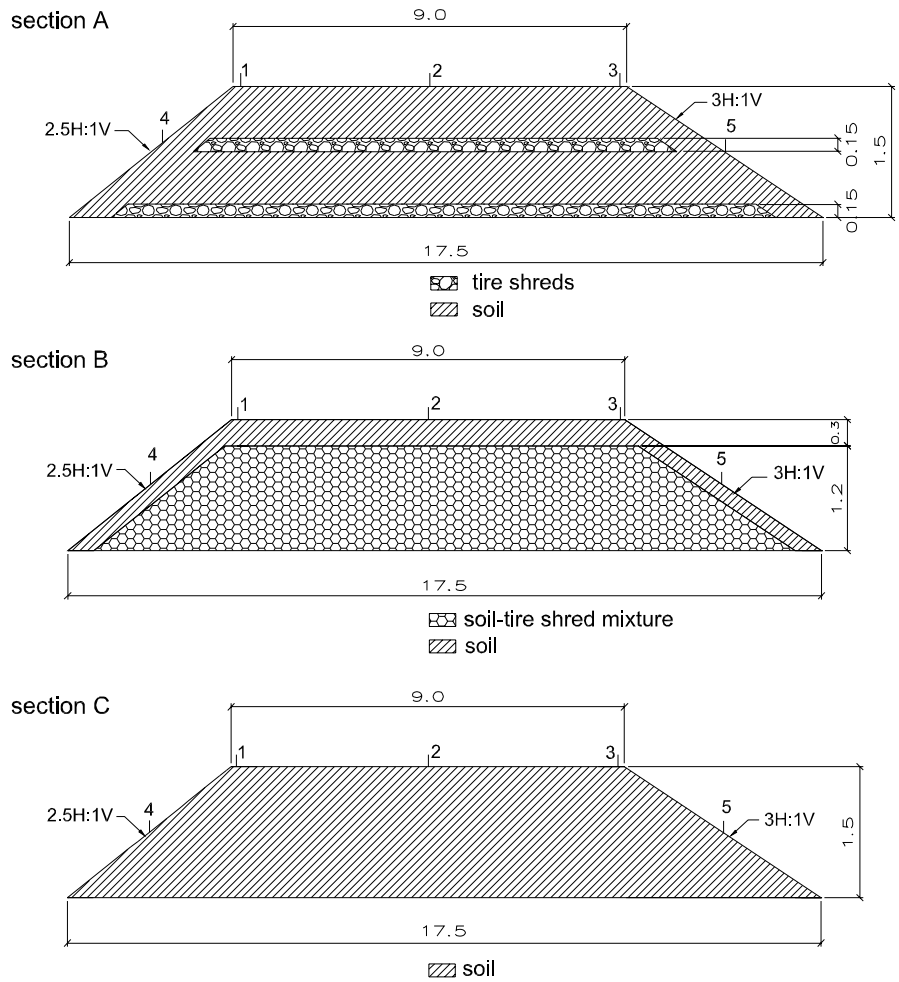

FIGURE 4 Prototype Embankment Cross-Sections Characteristics. Dimensions in meters.

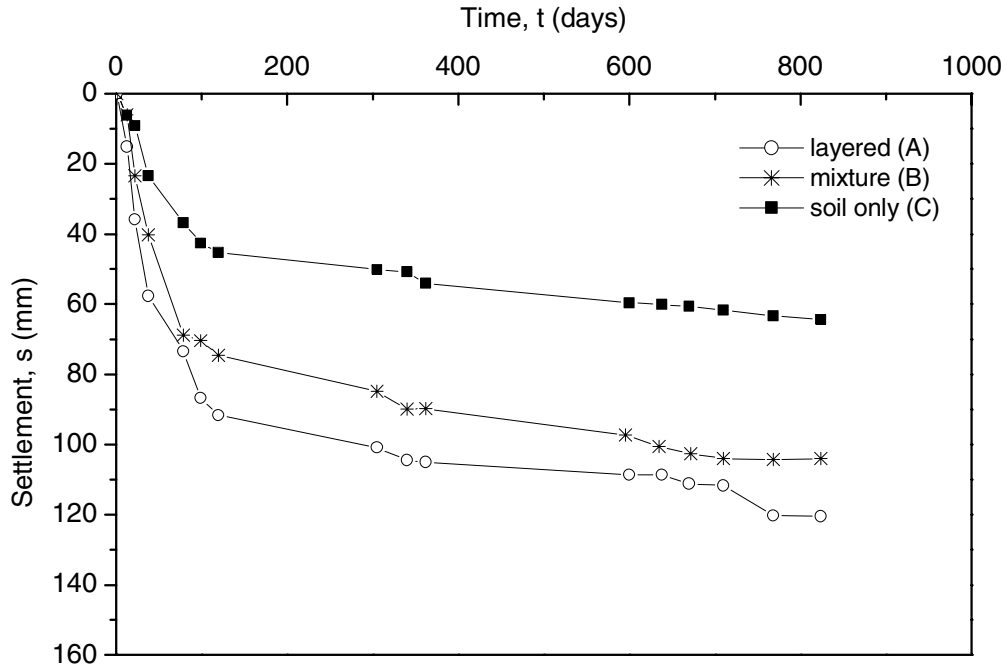

FIGURE 5 Settlement of Each Section After Construction and Submission to Traffic.

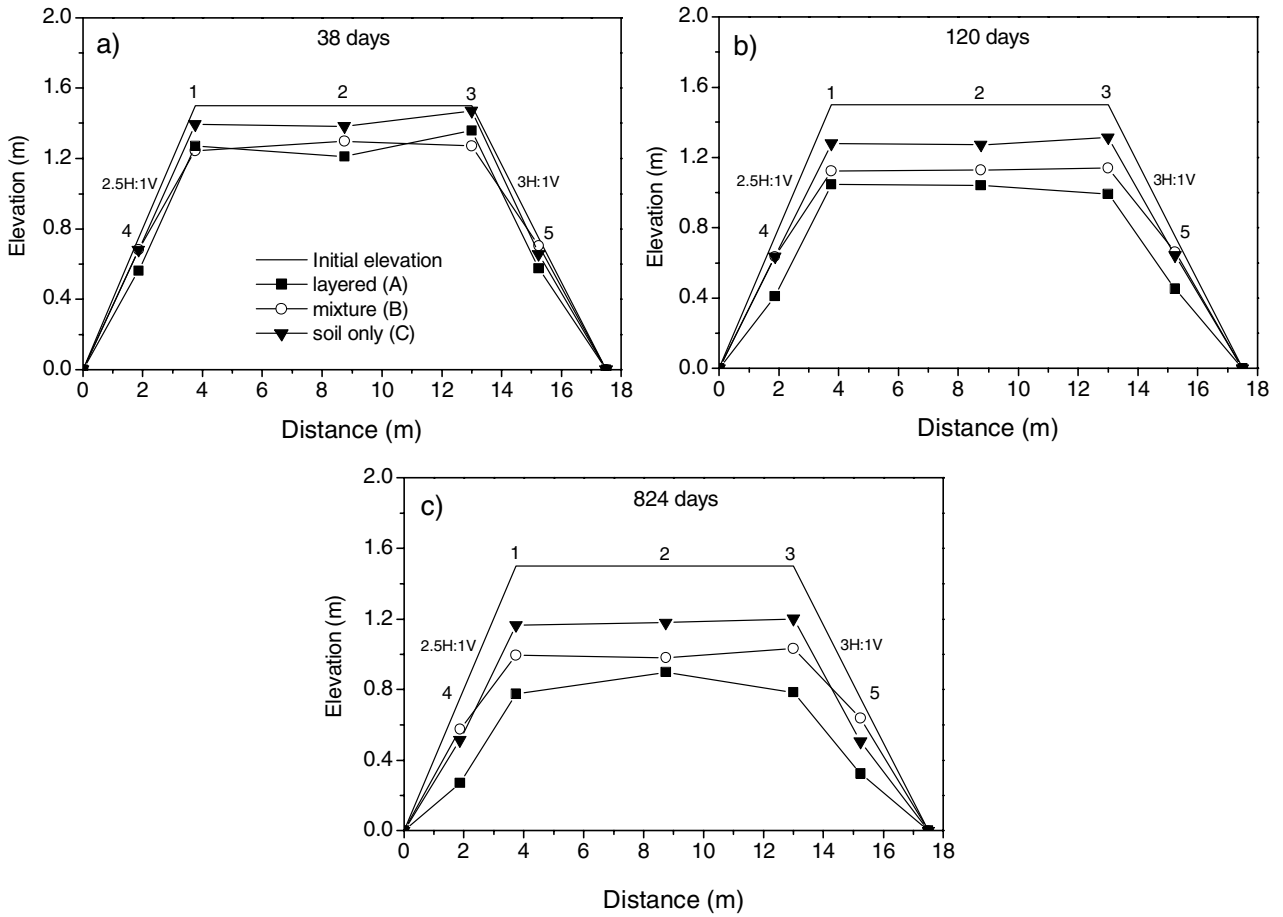

FIGURE 6 Settlement Profiles of the Embankment Cross-Sections at 38, 120 and 824 Days.
a) After 38 days, b) after 120 days, and c) after 824 days following construction.
Displacements are Magnified by a Scale Factor of 5.